

AIRTEC

INTERNATIONAL LTD



MASTER 35[®]

PETROL/GASOLINE IMPACT WRENCH

AIRTEC
INTERNATIONAL LTD

Couper Street, Glasgow G4 0DL United Kingdom

Tel: 44 (0) 141 552 5591

Fax: 44 (0) 141 552 5064

E-mail: enquiries@airtecintl.co.uk

This full Manual can be downloaded from our website www.airtecinternational.com in English, French, German & Spanish

MASTER 35[®]

PETROL/GASOLINE IMPACT WRENCH

MAINTENANCE MANUAL

DESCRIPTION	<u>CONTENTS</u>	PAGE NUMBER
Uses & Technical Information		1
Safety Precautions		2
Operating Controls - Illustrations		3
Operating Controls - Instructions for use		4
Start/Stop Operation		5
Routine Service		6
Dismantling Motor		7
Motor Parts List and Exploded Diagrams		8,9, 10
Motor Conversion Kit Parts List		11
Motor Notes		12
Dismantling Impact Unit		13
Gearbox Exploded Diagram Drawing and Parts List		14 & 15
Impact Unit & Carrying Handle Exploded Diagram Drawing and Parts List		16
Gearbox and Impact Unit Notes		17
Roll Bar Handle Kit		18
Fault Finding		19
Workshop Equipment		20
Accessories		21
Index		22 & 23

1. USES

The Master Impact Wrench is ideal for removing/fitting Chairscrews (Lag Screws) and Fishplates (Joint Bars) where track possession is not possible, if there are access difficulties or if other sources of power e.g. Air Compressors, Generators or Power Packs are not available. The Master can drill holes in Wooden Sleepers (Ties) using our Safety Quick Release Attachment which allows the fitting/removal of Auger Bits in seconds.

Fasteners can be removed/fitted in approximately five seconds.

2. TECHNICAL INFORMATION

1. TORQUE RANGE

500 - 1800 Nm (350 to 1325 Ft/lbs) using five position lever settings

2. BOLT CAPACITY

16 to 32mm (5/8" to 1 1/4")

3. DIMENSIONS

Length 570mm (22 3/8")
 Height 270mm (10 5/8")
 Width 445mm (17 1/2")

4. ENGINE - Two stroke/cycle Special Airtec EMAK 056 56 c.c.

Maximum free speed 12,000 R.P.M.

Fuel Tank capacity 0.7 litres (1.20 pints)

Running time on full tank of fuel 60 Minutes

Fuel Mixture ratios

Petrol/Gasoline Unleaded minimum 90 Octane and two stroke oil

OIL	MIX RATIO	MLS. PER LITRE	(OZS. PER US GAL.)
Mineral	25:1	40	3
Synthetic	50:1	20	1 1/2

5. EXHAUST EMISSION LEVELS

CO2 90g/Hph

HC 110g/Hph

6. GEARBOX

Fill with 0.25 Litre (0.44 pints) of Esso Spartan EP68 Gear Oil or equivalent to half way up sight glass with Wrench in the horizontal position.

When new, change oil after 1 hours use, after 5 hours and then every 30 hours.

7. IGNITION - Electronic Selectra

Spark Plug Champion RCJ-7Y or equivalent

Spark Plug gap 0.5 to 0.6mm

8. IMPACT MECHANISM

Fill with 130 grammes (4 1/2 oz) of Molybdenum Disulphate Grease, Castrol MS3, Klubern12MF or equivalent Grade 2 quality.

9. NOISE

Acoustic pressure (LpA) readings
 Idling 87 : dB(A)
 Acoustic power (LWA) according to ISO 3746 Idling 96 : dB(A)

Under very extreme working conditions the machine can reach 103 & 112 : dB(A) respectively.

10. SQUARE DRIVE

Standard 1"

11. VIBRATION based on actual on track tests

Can vary between 7.0 and 11.6 m/s² depending on operator technique and condition of Wrench, fastener and track but because the Wrench is so fast operator exposure is minimised.

It would be possible to fit/remove approximately 330 fasteners in an eight hour working day before reaching the Action Exposure level at 11.6 m/s².

The main **source** of **vibration** comes from technique and **Socket and Fastener**. Keep Fastener, Socket and Wrench in a straight line and ensure all are kept in good condition.

12. WEIGHT

18.3 Kgs (40 1/3 lbs)

3. SAFETY PRECAUTIONS

BEFORE using the Impact Wrench read these safety instructions **CAREFULLY** and ensure you fully **UNDERSTAND** them. **DO NOT** allow untrained personnel to use the Wrench.



1. Wear suitable **PROTECTIVE CLOTHING**, safety boots, goggles, gloves and ear protection according to Company rules, working conditions or Government/State Legislation.
Use of gloves may help prevent injury by keeping **hands warm** and dry.
For maximum safety wear ear protection within a 16 metre (17¹/₂ yards) distance of Wrench.
2. **FILL** the fuel tank carefully **BEFORE** starting the Wrench and avoid spillage. Use the Fuel Funnel provided and **DO NOT** fill or add oil while the Motor is running, if the tank is hot or it is close to any naked flames. Mix the quantity needed. Do not leave the mixture in the fuel tank or container for a prolonged period of time.
3. Use only **IMPACT QUALITY** Sockets and Accessories.
Using worn Sockets on a good Square Drive or good Sockets on a worn Square Drive will increase vibration levels with resultant damage to both operator and Wrench. **HAND** Sockets must **NEVER** be used.
4. Use Rubber Rings and Steel Pins or other suitable retaining devices to retain the Socket or Accessory onto the Square Drive. **DO NOT** use twigs, wire, nails or plastic straps.
5. Check the Wrench for damage regularly. Ensure fasteners are tight at all times.
A poorly maintained Wrench will be inefficient and produce extra noise and vibration.
6. Check pull cord is not frayed nor worn.
7. Know where the controls are and how to use them and be able to **STOP** the Wrench quickly in an emergency.
8. Do not wear hanging jewellery, a tie or **LOOSE** or torn clothing when using equipment.
9. **DO NOT** operate the Wrench in a **CONFINED** area, where exhaust fumes (**CARBON MONOXIDE**) may collect.
10. Set the **GEAR CONTROL** in **NEUTRAL** before starting.
11. Take up a **FIRM** footing and maintain a balanced body position.
12. Switch **OFF ENGINE BEFORE** transporting the Wrench to another location.
13. Take **CARE** when **LIFTING** or carrying the Wrench - weight with fuel and excluding accessory 18.3 Kgs (40 1/3 lbs).
14. Remove **FUEL FILLER CAP CAREFULLY** as pressure can build up in the tank. This is very important in warm weather, if the Wrench has been left in an exposed area or after prolonged periods of use.
15. Always auger or fit fasteners on one of the **LOW** torque settings and use a **HIGH** one for removing fasteners.

**SAFETY IS EVERYONE'S RESPONSIBILITY
THINK, ACT, BE SAFE**

4. OPERATING CONTROLS

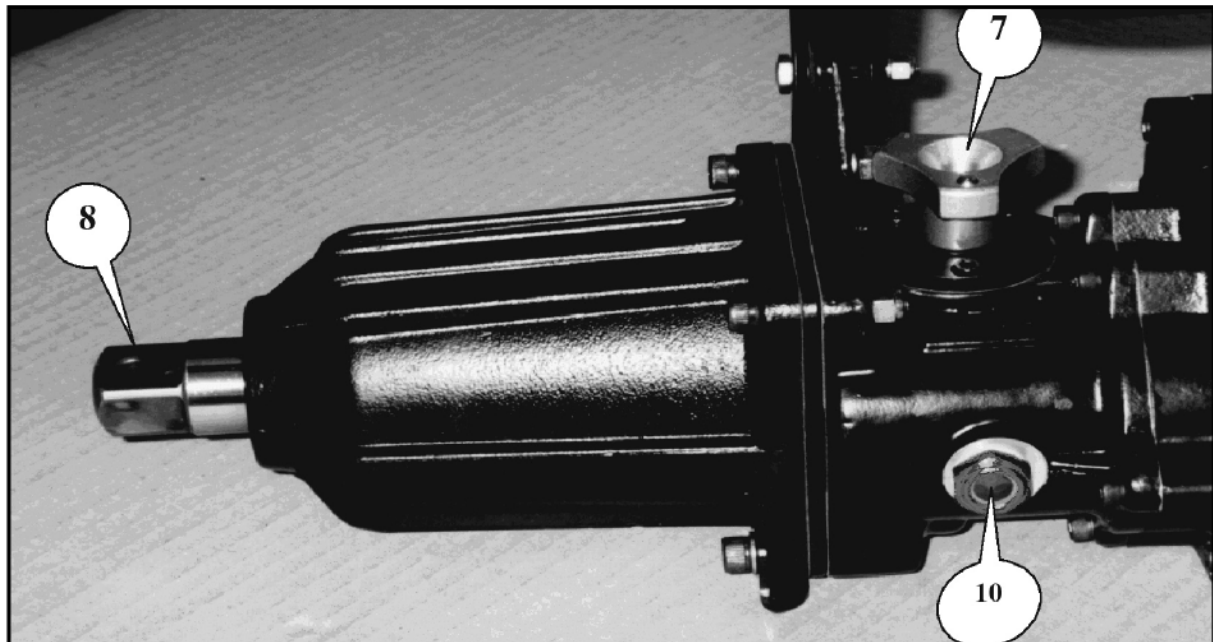
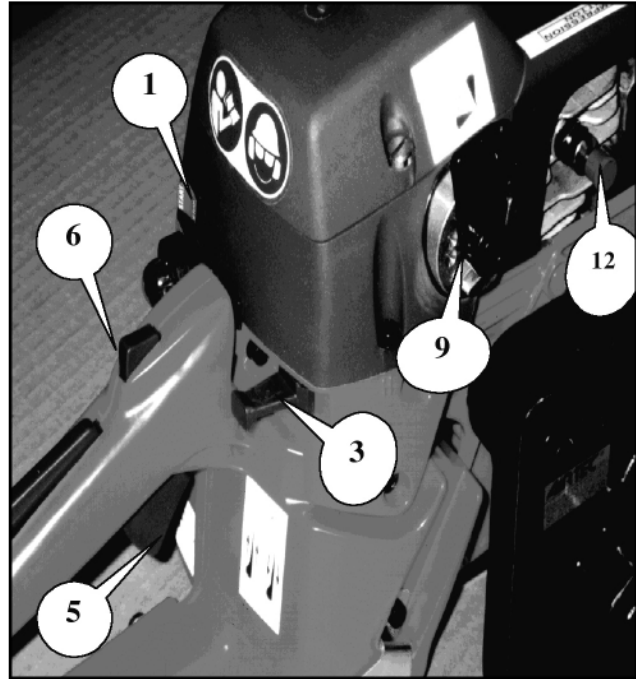
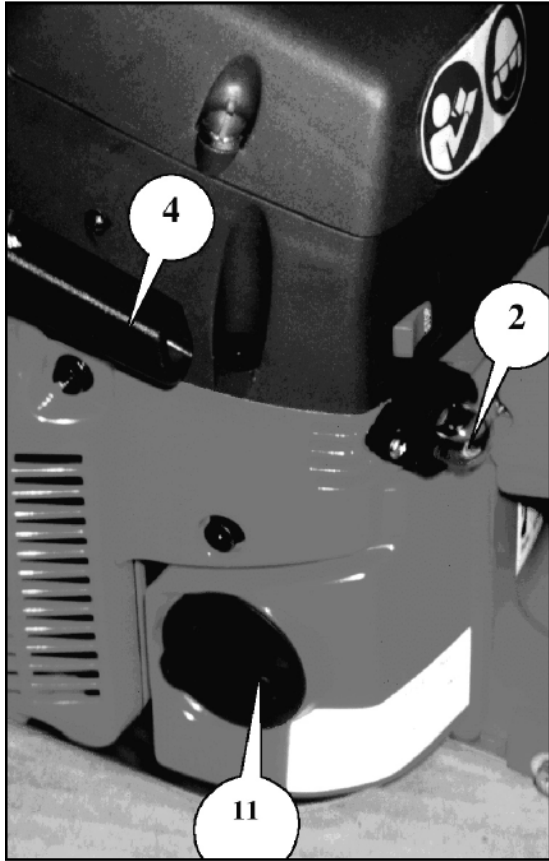

- | | | |
|---------------------------|--|----------------------------|
| (1) ON/OFF CONTROL SWITCH | (5) THROTTLE TRIGGER | (9) TORQUE SETTING LEVER |
| (2) FUEL PRIMER BULB | (6) HALF SPEED LEVER | (10) OIL FILLER PLUG |
| (3) CHOKE LEVER | (7) FORWARD/REVERSE/
NEUTRAL CONTROL KNOB | (11) FUEL FILLER CAP |
| (4) RECOIL STARTER | (8) SQUARE DRIVE | (12) DE-COMPRESSION BUTTON |

Note : The Serial Number can be found on Gearbox Casing, between Control Knob (7) and Oil Filler Cap (10)

5. OPERATING CONTROLS (See Page 3 for easy identification).

1. ON/OFF CONTROL SWITCH

To **START**, move the switch to **I**.
To **STOP** move to **STOP**.

2. FUEL PRIMER BULB

Makes starting easy.
Press bulb three/four times before using recoil starter handle.

3. CHOKE LEVER

Pull out to start and push in after Motor fires.



4. RECOIL STARTER

Start Motor by pulling the recoil starter handle.
Always allow the Starter Cord to return to its position under control and **DO NOT** allow it to fly back.

5. THROTTLE TRIGGER

When the throttle trigger is squeezed the Motor speed increases.

6. HALF SPEED LEVER

To operate hold down the lever, then release the trigger and it will hold in position.

7. FORWARD/REVERSE CONTROL KNOB

This has three positions: marked **N,F** and **R**
N - Neutral
F - Clockwise Rotation
R - Anti-clockwise Rotation
To engage turn **fully** 90 degrees from the Neutral position.
The gears are stationary when the Motor is idling at tickover speed. Select the gear required. If it will not engage, gently squeeze the throttle trigger so the gear parts move slightly.

8. SOCKET SQUARE DRIVE

Standard 1 inch Square Drive. The Accessory is secured to the Square Drive by a Rubber Ring and a 5mm dia Bright Steel Pin or other suitable retaining device. If the Pin breaks or bends examine both Accessory and Square Drive for possible wear.
Worn Accessories **damage the Square Drive**. A worn Square Drive **damages Accessories** and both create extra vibration.

9. TORQUE SETTING LEVER

This has five positions allowing a range of torques to be selected.
LOW settings normally 500Nm (350 Ft/lbs) and **HIGH** setting 1500Nm (1,100 Ft/lbs). For tightening fasteners and drilling use one of the **LOW** settings and for removing fasteners a **HIGH** one.

10. OIL FILLER PLUG

Use for filling, draining and indicating Gearbox oil level.

11. FUEL FILLER CAP

Remove carefully when refilling the Fuel Tank.

12. DE-COMPRESSION BUTTON

To assist in easy starting. Push in before starting. Comes out automatically when Motor Starts.

CAUTION - REFUELLING
OPEN TANK CAUTIOUSLY TO
RELEASE ANY PRESSURE SLOWLY
USE 2 STROKE/CYCLE OIL MIX ONLY
25:1 Mineral
50:1 Synthetic

6. START/STOP OPERATION

1. FUEL MIXTURE

Mix = 1:25 Mineral or 1:50 Synthetic Oil to unleaded Petrol/Gasoline. Mix Oil and Petrol/Gasoline thoroughly in a separate container before filling the tank.

REMEMBER: Using **too much** Oil will oil up the Spark Plug and **too little** causes extra wear.

2. PREPARATION FOR START-UP

Check oil level in the gear box is correct and that all nuts and screws are tight. Fill the fuel tank with the correct mixture

3. STARTING THE WRENCH

Place Wrench on a **SOLID** base and take a comfortable stance.

Slide Accessory onto Square Drive and secure with a Steel Pin and Rubber Ring or appropriate retaining device.

Set gear control in **NEUTRAL (N)**.

Push in De-Compression Button (12).

Pull choke lever (3) out.

Set ON/OFF Switch (1) to position I.

Fill Carburettor by pushing Fuel Primer Bulb (2) three/four times.

Pull the throttle trigger (5) stop it at half-throttle and hold down the half speed lever (6), and release trigger.

Place **heel** of boot on the extended Handle base or Roll Bar if fitted and pull the Recoil Starter slowly until resistance is felt, then pull hard several times. When the Motor fires return Choke lever (3) to its original position.

Once the Motor starts, press throttle trigger (5) to release it from the halfthrottle position and allow Motor to idle. Before using the Wrench warm up for a minimum period of thirty seconds.

NEVER accelerate to high speeds when in neutral.

4. OPERATING THE WRENCH

Always follow the "**SAFETY PRECAUTIONS**" shown on Page 2.

Position Wrench and Socket over fastener to be tightened/loosened and keep all three in a straight line.

Set Torque Lever and select the gear by moving gear control fully 90° to position F or R.

5. STOPPING THE WRENCH

Release throttle trigger and let Motor return to idle.

Turn off Motor by moving ON/OFF Switch to STOP position.

Set the Gear Control to **neutral (N)**

6. RE-FUELLING

ALWAYS open the Fuel Filler Cap **carefully** to release any pressure which may have built up. Cold fuel expands in a hot tank.

7. TUNING

The Carburettor is Factory set to meet E.P.A. regulations with Screws locked to permit only a half turn movement.

Do not force them further or the plastic cap locks will break.

Emission levels could then be in excess of the figures stated in our literature.

If the cap locks should be broken

accidentally reset the Carb. screws :-

Turn the high screw clockwise until it stops then anticlockwise 2¹/₈ - 2¹/₄ turns.

Repeat this with the low screw setting at 1¹/₄ - 1¹/₂ turns.

These are basic settings and further slight adjustments may be necessary because of changes in climatic conditions and altitude. Keep adjustments to a minimum.

T	idling speed	2,500 to 2,800 RPM
H	maximum free speed	12,000 RPM

Once the Motor is warm **DO NOT** use the choke to start again.

Use the half throttle only when starting the engine.

DO NOT FILL OIL CHAMBER AT THE FRONT OF THE MOTOR



OPERATION & MAINTENANCE AIDS AVAILABLE

Operation Manual

Maintenance Manual

C.D. Rom - Safety Applications

Exploded Diagram Workshop Drawings

WEBSITE : www.airtecinternational.com

7. ROUTINE SERVICE (See Exploded Diagram Drawings on Pages 8, 9, 10, 14 & 16)

- 1. REPLACING SPARK PLUG 4000.0809**
Loosen two Filter Cover Screws 0180 and lift off Filter Cover 0990. Pull off Spark Plug Cover 0250. Unscrew Spark Plug and replace making sure the gap is set at between 0.5 and 0.6mm.
- 2. REPLACING AIR FILTER 4003.0451**
Pull Air Filter 0451 from inside the Filter Cover 0990. Clean Filter and Filter Cover or if necessary, replace.
- 3. REPLACING FUEL FILTER 4001.9100**
With the Machine in a vertical position open Fuel Cap 1090 cautiously to release any build up of pressure in the Fuel Tank. Pull out Fuel Filter and replace.
- 4. REPLACING STARTER CORD 4003.0340**
Remove four Screws 0410 holding Starter Assembly 1162. Hold Pulley 0360 with thumb, cut old cord and allow Pulley to turn slowly back until no tension is left in Recoil Spring 04501. Remove Centre Screw 0690 and Washer 0700 and slowly lift off pulley. Fit new Cord through pulley and tie a knot. Feed other end of Cord through Starter Housing 1043 and into Starter Handle 0400 and again tie a knot. Locate Pulley in Recoil Spring and replace Centre Screw 0690 and Washer 0700. Locate Cord in the notch on outside of pulley, turn clockwise two complete turns then release. Repeat until the Starter Handle returns to the Housing locating hole when pulled out. Ensure correct length Screws 0410 are used when re-assembling.

- 5. REPLACE GEAR BOX OIL**
Remove three Screws 58 in Gear Selector 46 and remove from Gear Box. Empty out old oil. Fill gearbox with 0.88 pints (0.5 litres) of EP68 Gear Oil. Replace Selector and fit screws using a suitable fastener locking fluid.
When the Wrench is new change gearbox oil after one hours use, after five hours and then every thirty hours on a routine basis.

- 6. GREASING HAMMER AND ANVIL**
Remove four Screws 90, 91, 95, Nuts 62 and Nose Casing. Clean out old grease and replace with 130grammes (4 1/2 ozs) of new Molybdenum Disulphate Grease Grade 2. Ensure this is pumped into holes on the side of Hammer Casing 83 and onto all eight striking faces.

7. ROUTINE MAINTENANCE INSTRUCTIONS
It is recommended a record of inspections and maintenance is kept and each Wrench is given a routine maintenance check after every 50 Hours use. This will reduce maintenance costs, improve efficiency and extend its useful life.

<u>OPERATOR DAILY</u>	Check all Bolts, Screws and Nuts for tightness and gearbox oil level.
WEEKLY	Clean Air Filter and Fuel Filter. If necessary use a suitable Solvent.
MONTHLY or every 25 hours use	Clean Spark Plug and check gap is 0.5 - 0.6mm Change Gearbox Oil.
QUARTERLY or every 50 hours use	As above plus following:- Clean internal Hammer and Anvil faces thoroughly and replace Grease. Change Fuel Filter.

Use only GENUINE MASTER SPARE PARTS
Use of non-original parts reduces Wrench life, cancels Warranty and affects Product Liability cover.

8. DISMANTLING MOTOR (See Exploded Diagram Drawings on Pages 8, 9, 10, 14 & 16

1. REPLACE AIR FILTER 4003.0451

Unfasten two Screws 0180 on Filter Cover 0990 and lift off. Remove and replace Air Filter.

2. REMOVING TOP COVER 2870.1100

Loosen three Screws 0480. Push rubber air intake 0770 through Top Cover. Remove wires from On/Off Switch 0491 noting position for re-connecting. Refit using Air Intake Tool Part No. 4002 9005.

3. REPLACING FUEL PRIMER ASSEMBLY 4003.0810

Remove Screws 2303.0315 and take off Bulb Protector 2650.1010 and pull Primer from Motor.

Please note : for Primer re-connection connect Pipe 1190 from Fuel Tank to "out" port and Pipe 0910 from the Carbrettor "in" port.

4. REPLACING STARTER RECOIL SPRING 4003.04501

Follow procedure for replacing Pull Cord - See 7.4 on Page 6.

With the pulley separated from Starter Housing, remove the two Screws.

Remove old Spring Cassette and replace with new one. Refit screws.

When refitting Starter Housing pull Starter Cord to ensure it operates before tightening Screws.

Please Note:
The Spring in the Cassette Case is pre-tensioned. Always handle with care



5. REMOVING FLYWHEEL 4003.1186

Fit Piston Stop Tool 10.00022 into Cylinder and remove Flywheel Nut 0040. Remove Flywheel Ratchet Assembly 1187. Using Puller 10.00049 with Screws 10.00362 remove Flywheel. Take care not to lose Key 0220.

6. REMOVING EXHAUST GUARD 8 AND MUFFLER ASSEMBLY 4003.0850

Remove five Screws 7 holding Exhaust Guard and lift off. Unfasten two Screws 0640 on inside of Exhaust Box and remove it and Gasket 0860 from Motor.

Ensure Motor/Muffler is warm when re-fitting Screws

7. REMOVING THE CARBURETTOR 4003.0510

Remove two Screws 0080, Screw 0720 and Fuel Pipes 0190 & 0920 from Carburettor making sure to note re-connecting positions. Disconnect Choke Linkage 0880 and Throttle Linkage 1020 and remove Carburettor.

8. DISMANTLING MOTOR FROM IMPACT UNIT

Remove Carrying Handle 97 and four Screws 24 holding Clutch Support Flange 18 to Engine Flange 9. Pull apart.

9. REMOVING CYLINDER AND PISTON 4003.1165

Remove three Screws 0410 holding Carburettor Flange 0740 to Casing. Depress Spring Clip 0390 behind Carburettor Flange and pull from Cylinder. Loosen four Screws 0630 holding down Cylinder and lift off. Remove Spring Clip 4001 4200 from inside Piston and Gudgeon Pin 0800. Lift off Piston 1120. Check Piston Rings 0820 for wear and replace if necessary. Rebuild in reverse order.

Please Note: If Clutch is to be removed leave Cylinder and Piston in position until after this is done.

10. REMOVING CRANKCASE 4003.1150 & 4003.1169 FROM FUEL TANK 4003.1045

Remove Screws 0110 to allow Crankcase to be disconnected from Fuel Tank.

11. REMOVING CRANKSHAFT 4003.0985

Remove seven Screws 4001.1100 from Clutch side of Crankcase. Run Flywheel Nut 0040 onto Crankshaft 0985 until flush with the end. Hold Crankcase tightly and using a soft faced mallet tap against the Flywheel Nut until the Casing splits.

Please Note: a) It is advisable to replace all Gaskets and Seals when rebuilding Motor.

b) If Primer Bulb 0810 is burst disconnect two Fuel Pipes 0910 and 1190 and plug the holes.

DO NOT CONNECT THE PIPES TOGETHER Replace Primer Bulb Assembly as soon as possible. (see section 8.3)

9. MASTER MOTOR PARTS LIST

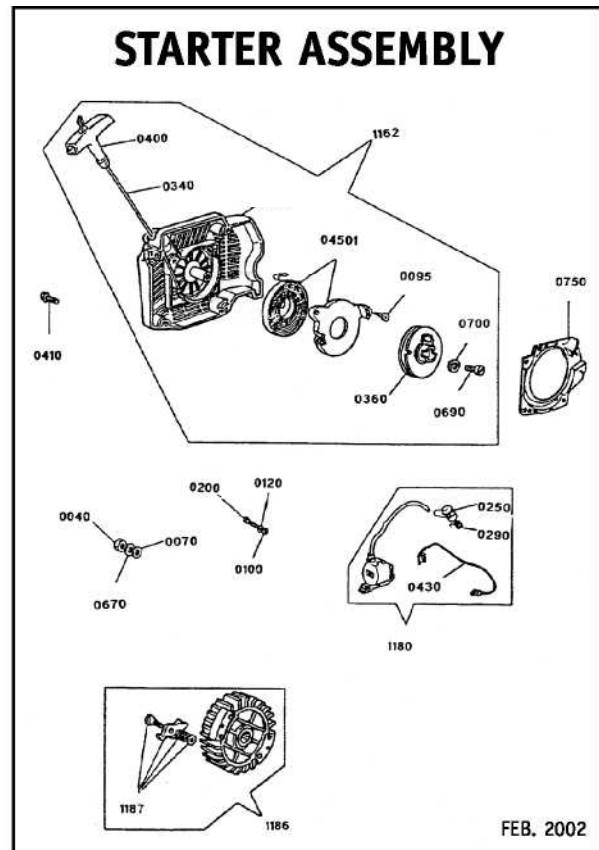
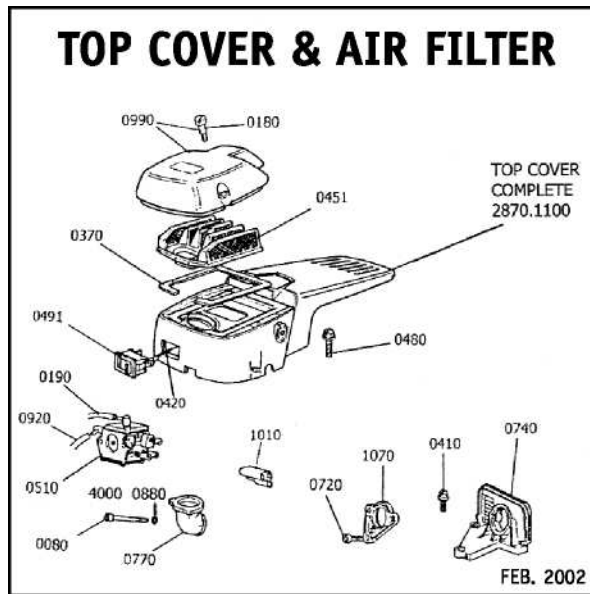

TOP COVER AND AIR FILTER

Part. No.	Description
2870 1100	Top Cover Complete (See Note 4, Page 12)
4000 0880	Washer (2)
4003 0080	Screw (2)
4003 0180	Screw (2)
4003 0190	Pipe
4003 0370	Gasket
4003 0410	Screw (3)
4003 0420	Lead
4003 0451	Air Filter
4003 0480	Screw (3)
4003 0491	On/Off Switch (See Note 2 Page 12)
4003 0510	Carburettor (AT version)
4003 0720	Screw
4003 0740	Carburettor Flange
4003 0770	Rubber Air Intake
4003 0920	Pipe
4003 0990	Air Filter Cover
4003 1010	Screen Guide
4003 1070	Spacer

STARTER ASSEMBLY

Part. No.	Description
4003 0040	Nut
4003 0070	Washer (50.00361)
4003 0095	Screw (2)
4003 0100	Washer (2)
4003 0120	Washer (2) (60.00315)
4003 0200	Screw
4003 0250	Plug Cap
4003 0290	Spring
4003 0340	Recoil Starter Cord
4003 0360	Pulley
4003 0400	Handle
4003 0410	Screw (4)
4003 0430	Lead
4003 0670	Washer
4003 0690	Screw
4003 0700	Washer
4003 0750	Flange Cover
4003 1162	Starter Assembly (See Note 11 Page 12)
4003 1180	Coil Assembly
4003 1186	Flywheel Assembly (See Note 2 Page 12)
4003 1187	Flywheel Ratchet Assembly
4003 04501	Recoil Spring Assembly

10. MASTER MOTOR PARTS LIST

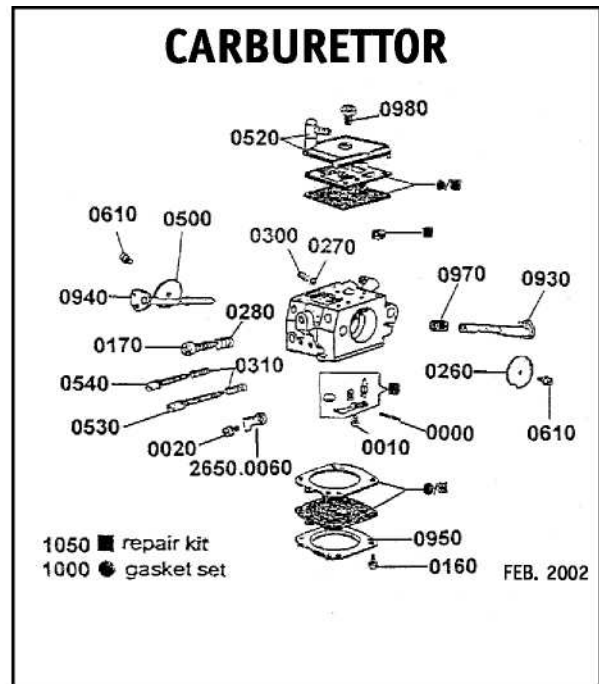
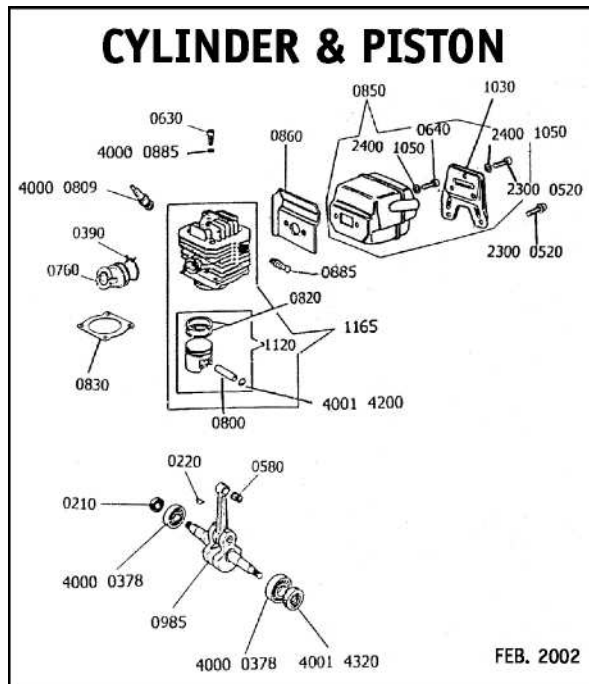

CYLINDER & PISTON

Part. No.	Description
2300 0520	Screw (5) (AT version)
2400 1050	Washer (5) (AT version)
4000 0378	Bearing (2)
4000 0809	Spark Plug
4000 0885	Washer
4001 4200	Spring Clip (2)
4001 4320	Seal
4003 0210	Seal
4003 0220	Key
4003 0390	Spring Ring
4003 0580	Bearing
4003 0630	Screw (4)
4003 0640	Screw (2)
4003 0760	Manifold
4003 0800	Gudgeon Pin
4003 0820	Piston Ring (2) 46mm dia
4003 0830	Gasket
4003 0850	Muffler Assembly (AT version)
4003 0860	Gasket Insulator
4003 0885 *	De-Compression Button(See Note 1 Page 12)
4003 0985	Crankshaft
4003 1030	Muffler Cover
4003 1120	Piston Assy 46mm dia(See Note 7 Page 12)
4003 1165 *	Cylinder Assembly 46mm dia (See Note 1 Page 12) *Order together

CARBURETTOR

2650 0060	Throttle Stop (AT version)
4003 0000	Pin
4003 0010	Screw (33.00202)
4003 0020	Screw (33.00209)
4003 0160	Screw (4) (50.00162)
4003 0170	Screw
4003 0260	Throttle
4003 0270	Ball
4003 0280	Spring
4003 0300	Spring
4003 0310	Spring (2)
4003 0500	Shutter Disc
4003 0520	Cover
4003 0530	Screw
4003 0540	Screw
4003 0610	Screw (2)
4003 0930	Shaft Assembly Throttle
4003 0940	Shaft Assembly Choke
4003 0950	Cover
4003 0970	Spring
4003 0980	Screw
4003 1000	Walbro Carburettor Gasket Set
4003 1050	Walbro Carburettor Repair Kit

11. MASTER MOTOR PARTS LIST

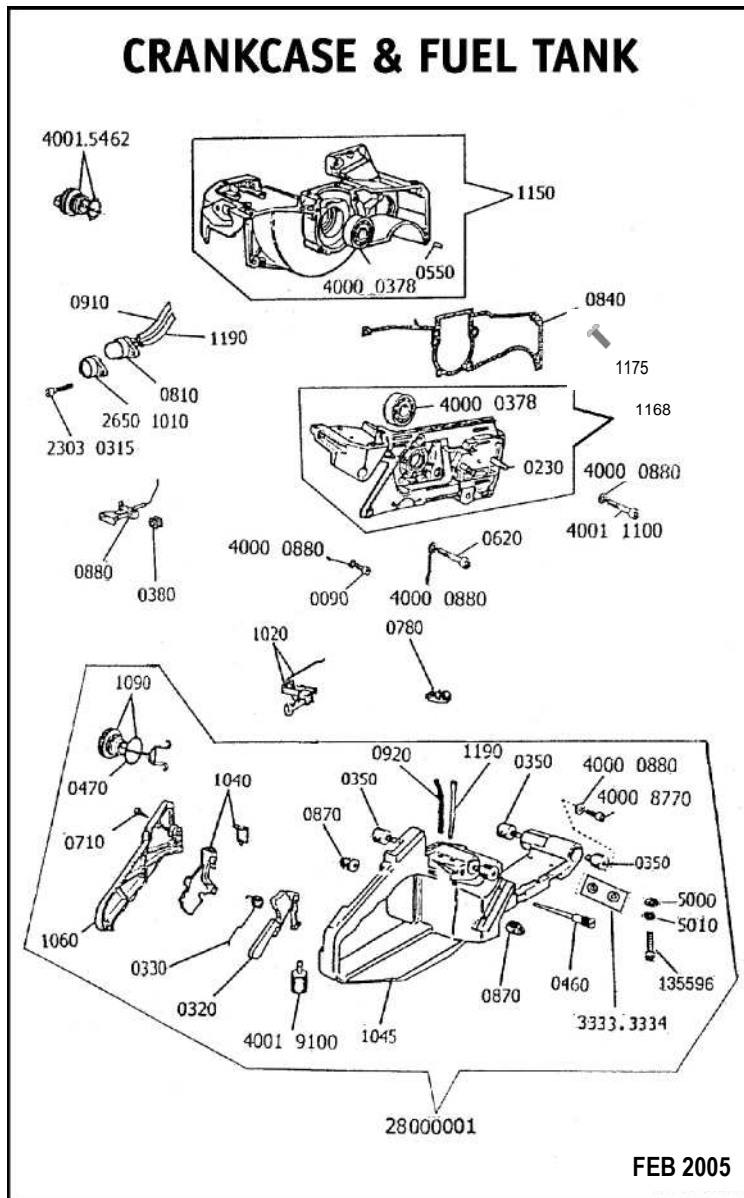

CRANKCASE & FUEL TANK

Part. No.	Description
135596	Screw M5 x 25
2303 0315	Screw (2) (AT version)
2650 1010	Bulb Protector
2800 0001	Fuel Tank Complete Assy.
3333 3334	Backing Plate
4000 0880	Washer (11)
4000 0378	Bearing (2)
4000 8770	Screw (4)
4001 1100	Screw (2)
4001 9100	Fuel Filter
4001 5462	Cap
4003 0090	Screw
4003 0230	Stud Bolt (2)
4003 0320	Throttle Lock
4003 0330	Spring
4003 0350	Rubber Mount (4)
4003 0380	Grommet
4003 0460	Breather
4003 0470	'O' Ring
4003 0550	Pin (2)
4003 0620	Screw (4)
4003 0710	Screw (3)
4003 0780	Grommet
4003 0810	Primer Assembly
4003 0840	Gasket
4003 0870	Rubber Mount (2)
4003 0880	Choke Linkage
4003 0910	Pipe Tubing
4003 0920	Pi pe
4003 1020	Throttle Linkage
4003 1040	Lever
4003 1045	Fuel Tank Only(See Note 5 Page 12)
4003 1060	Handle Cover
4003 1090	Fuel Cap
4003 1140	Gasket Set
4003 1150	Half Crankcase
4003 1168	Half Crankcase
4003 1175	Stud Bolt
4003 1190	Pipe Tubing

12. MASTER CONVERSION KIT PARTS LIST

CONVERSION KIT 2810.1004
TO CONVERT STANDARD MASTER 35
INTO NEW STYLE

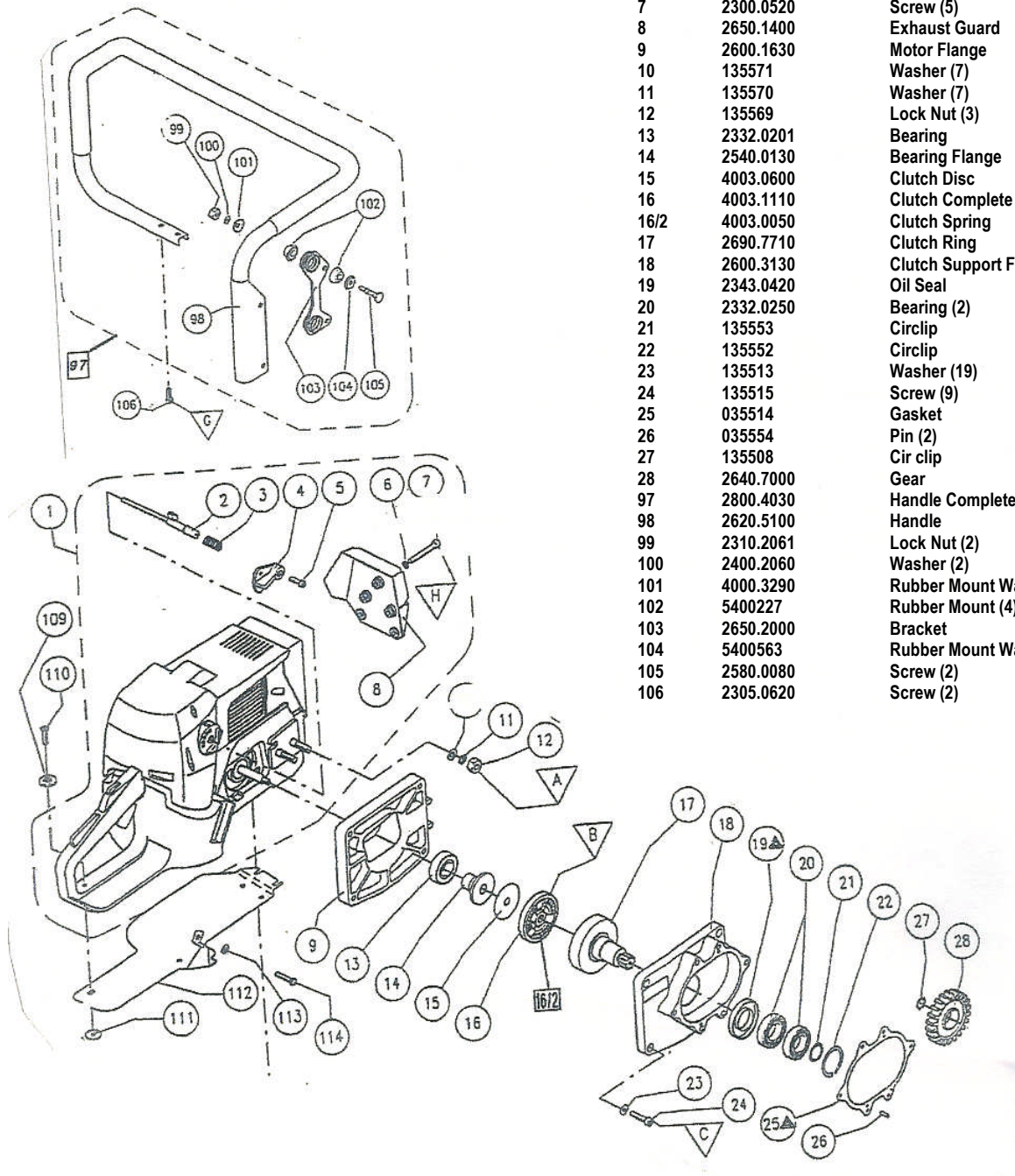

DRWG REF.	PART NO.	DESCRIPTION
1	2810.1030	Motor Complete
2	2570.0050	Cam with Shaft
3	2510.0030	Regulator Spring
4	035588	Torque Control Lever
5	135593	Screw
6	135597	Washer (5)
7	2300.0520	Screw (5)
8	2650.1400	Exhaust Guard
9	2600.1630	Motor Flange
10	135571	Washer (7)
11	135570	Washer (7)
12	135569	Lock Nut (3)
13	2332.0201	Bearing
14	2540.0130	Bearing Flange
15	4003.0600	Clutch Disc
16	4003.1110	Clutch Complete
16/2	4003.0050	Clutch Spring
17	2690.7710	Clutch Ring
18	2600.3130	Clutch Support Flange
19	2343.0420	Oil Seal
20	2332.0250	Bearing (2)
21	135553	Circlip
22	135552	Circlip
23	135513	Washer (19)
24	135515	Screw (9)
25	035514	Gasket
26	035554	Pin (2)
27	135508	Cir clip
28	2640.7000	Gear
97	2800.4030	Handle Complete
98	2620.5100	Handle
99	2310.2061	Lock Nut (2)
100	2400.2060	Washer (2)
101	4000.3290	Rubber Mount Washer (2)
102	5400227	Rubber Mount (4)
103	2650.2000	Bracket
104	5400563	Rubber Mount Washer (2)
105	2580.0080	Screw (2)
106	2305.0620	Screw (2)

Last Serial No. for STANDARD Master 35
First Serial No. for NEW Master 35

ATD 00A44 approximately December 1999
ATE 99A01 approximately January 2000

13. MASTER MOTOR PARTS LIST NOTES

1. Cylinder 4003.1130 replaced by De-Compression version 4003.1165 and Button 4003.0885 from Serial No. ATE00M01
2. Part Number Changes

Old	Description	New
2650.0050	Throttle Stop	2650.0060
4000.1620	Spark Plug	4000.0809
4001.5461	Cap	4001.5462
4003.0440	Ratchet Assy.	4003.1187
4003.0450	Air Filter	4003.0451
4003.0490	On/Off Switch	4003.0491
4003.0730	Crankshaft	4003.0985
4003.0790	Flywheel Assy.	4003.1186
4003.0890	Starter Housing	4003.1043 **
4003.1025	Screw	4003.0610
4003.1080	Starter Assy.	4003.1162
4003.1160	Half Crankcase	4003.1169
3. Top cover only 4003.1170 no longer available. (05.03.01).
4. Top Cover complete 2870.1100 comprises the following parts:-

Top Cover	4003.1170
On/Off Switch	4003.0491
Gasket	4003.0370
Cam with Shaft	2570.0050
Regulator Spring	2170.0030
Torque Control Lever	035588
Screw	135593
5. Fuel Tank only 4003.0900 replaced by 4003.1045.
6. Recoil Spring 4003.0030 now supplied as an Assembly 4003.04501
7. Piston Assembly 4003.1120. When ordering please advise the type e.g. A, B, C or D. This can be found on top of the cylinder.
8. STANDARD MASTER 35 Impact Wrench can be converted into new style using Motor Conversion Kit Part No. 2810.1004.
9. Stud Bolt 4003.1175
Replaces Stud Bolt 4003.0230 from Machine No. 02L044
10. Muffler Screw 2300.0520
Please ensure Motor Muffler is hot when fitting these. Tightening torque 9Nm
If tightened when cold Screws will not hold.
- **
11. Starter Housing 4003.1043 no longer available 01/02/06. Order Starter Assembly 4003.1162.

14. DISMANTLING IMPACT UNIT (See Exploded Diagram Drawings on Page 16).

1. REMOVING CLUTCH SUPPORT FLANGE 18

Remove Gear Selector 46 and empty oil from Gearbox 30. Remove six Screws holding Clutch Support Flange to Gearbox and pull apart.

2. REMOVING CLUTCH 16 AND MOTOR FLANGE 9

Remove Spark Plug 0060 and fit Piston Stop Tool 10.00022. Turn Clutch Nut 16 in clockwise direction. Loosen two Lock Nuts 12 holding Motor Flange to Motor and pull off Flange.

To replace Motor Flange Bearing 13 press out and replace. Assemble in reverse order.

3. REPLACING SEAL 19 & BEARINGS 20 IN CLUTCH SUPPORT FLANGE 18

Remove Circlip 21 and using a soft face mallet tap out Clutch Ring 17. Remove Circlip 22 and from the opposite side push out Bearings 20. Remove Oil Seal 19 and replace if necessary. Assemble in reverse order.

4. DISMANTLING GEARBOX 29

Remove Circlip 27 and lift off Gear 28. Remove Ring Flange 67 and check Bearings 66 & 69 and Oil Seal 68 for wear or damage. Remove Bearing Shaft 42 and check. Remove Circlip 31 and from the opposite side tap out Selector Shaft 33. Using a 5mm Screw extract Planet Pivot 39 by holding the Screw Head in a vice and tap Gearbox with a soft face mallet. Remove Planet Gear 38 and Spacer 36.

Please Note: The Planet Gear has a chamfered edge which MUST be re-fitted in the same way as before.

Take out Gear Cluster 41 and note directions for re-building. Assemble in reverse order.

5. DISMANTLING HAMMER COMPLETE 78

Place complete Hammer length ways in a vice with one hole uppermost. Carefully tighten vice until Steel Ball 76 drops out of lower hole (a short blast of air will assist this operation). Loosen vice and turn Hammer 83 through 180° degrees and repeat previous instruction to allow second ball to be removed. Slowly loosen vice again. Hammer Casing 83 and Catch 71 can now be separated. Remove Shaft 75, Spring 77 and Bearing 74 and inspect for wear. Using Circlip Pliers remove Seeger Rings 79 from Hammer Casing. Tap off Steel Ring 80 with a punch, Knock out four Steel Plugs 82 from inside to allow Cam 81 to be removed from Hammer Casing.

Please Note: Always renew the Steel Plugs before rebuilding.

Inspect Anvil 84 and Hammer 83 striking faces for wear or damage. These are critical areas which will affect the Wrench's performance.

Inspect all parts for wear or damage and replace, grease up and re-build in reverse order.

Fit new Gasket 85 and refit Nose Casing 86.

Please Note: It is advisable to replace Seals, 'O' Rings and Gaskets when re-building the Impact Unit.

15. **MASTER IMPACT PARTS LIST**

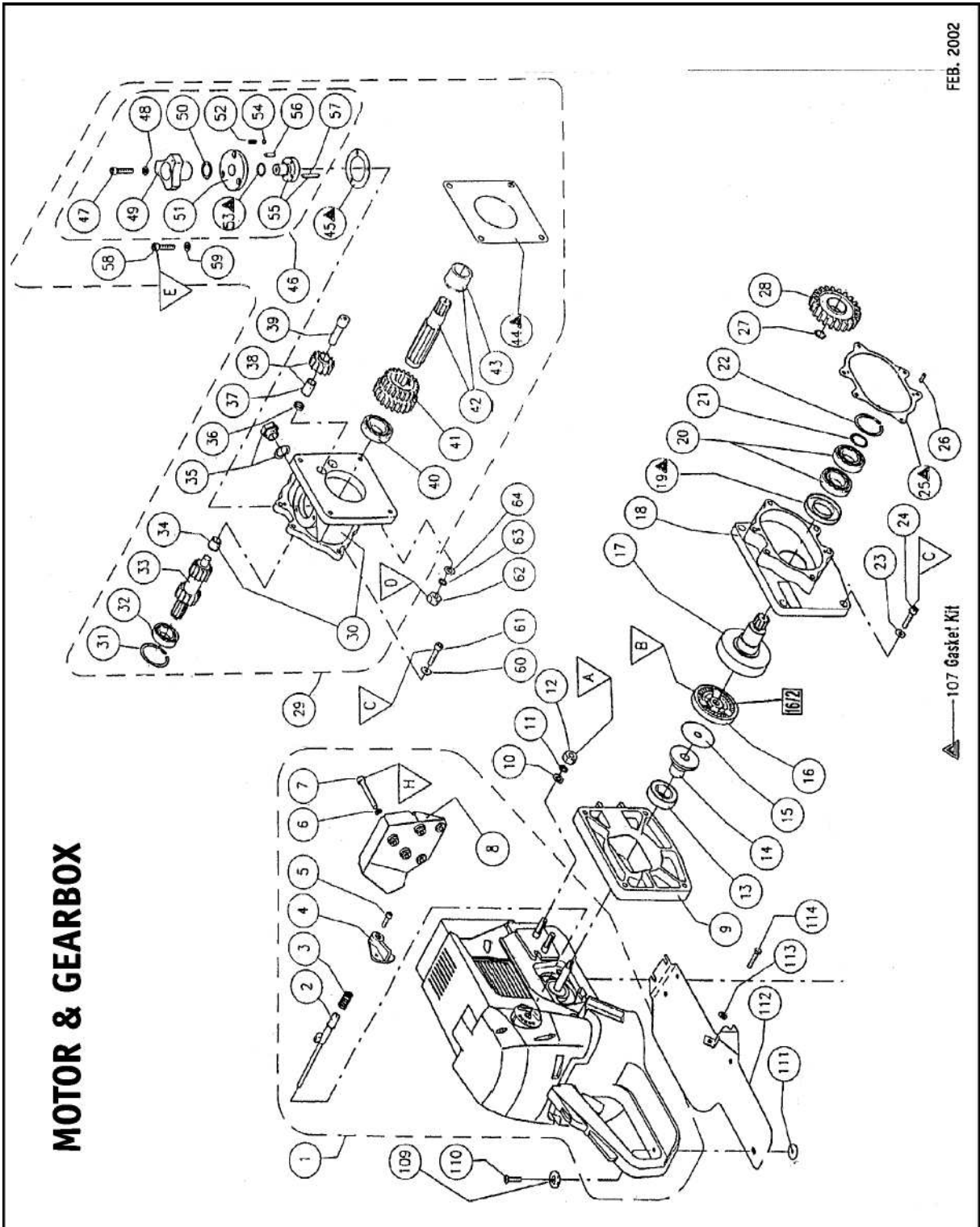

Note : Fastener torques shown on Page 17

MOTOR & GEARBOX PARTS LIST

DRG. REF	PART NO.	DESCRIPTION
1	2810.1030	Motor Complete
2	2570.0050	Cam with Shaft
3	2510.0030	Regulator Spring
4	035588	Torque Control Lever
5	135593	Screw
6	135597	Washer (5)
7	2300.0520	Screw (5)
8	2650.1400	Exhaust Guard
9	2600.1630	Motor Flange
10	135571	Washer (7)
11	135570	Washer (7)
12	135569	Lock Nut (3)
13	2332.0201	Bearing
14	2540.0130	Bearing Flange
15	4003.0600	Clutch Disc
16	4003.1110	Clutch Complete
16/2	4003.0050	Clutch Spring
17	2690.7710	Clutch Ring
18	2600.3130	Clutch Support Flange
19	2343.0420	Oil Seal
20	2332.0250	Bearing (2)
21	135553	Circlip
22	135552	Circlip
23	135513	Washer (19)

DRG. REF.	PART NO.	DESCRIPTION
24	135515	Screw
25	035514	Gasket
26	035554	Pin (2)
27	135508	Circlip
28	2640.7000	Gear
29	035305	Gasket complete
30	035105	Gearbox Casing c/w Bronze Bush 34
31	135516	Circlip
32	102020	Bearing
33	035119	Selector Shaft
34	035106	Bronze Bush
35	135520	Oil Plug & Felt Washer
36	035550	Spacer
37	0335548	Bronze Bush
38	035551	Planet Gear c/w Bronze Bush 37
39	035549	Planet Pivot
40	103020	Bearing
41	035104	Gear Cluster
42	035102	Bearing Shaft c/w Bush 43
43	035103	Bush
44	035560	Gasket
45	035115	Gasket
46	035304	Gear Selector Complete
47	135506	Screw

DRG. REF.	PART NO.	DESCRIPTION
48	135513	Washer
49	035107	Gear Change Knob
50	135110	Bevel Washer
51	035111	Gear Flange
52	035523	Spring
53	135114	'O' Ring
54	104051	Ball
55	035112	Gear Selector
56	035554	Pin
57	035113	Selector Pin
58	135116	Screw (3)
59	135597	Washer (7)
60	135513	Washer (19)
61	135515	Screw (9)
62	135569	Lock Nut
63	135570	Spring Washer (3)
64	135571	Washer
107	2890.1050	Gasket Kit
109	2700.0220	Washer
110	2304.0520	Screw
111	2700.0200	Threaded Plate
112	2650.1050	Fuel Tank Wear Plate
113	2400.2060	Washer
114	2305.0620	Screw

17. MASTER IMPACT PARTS LIST

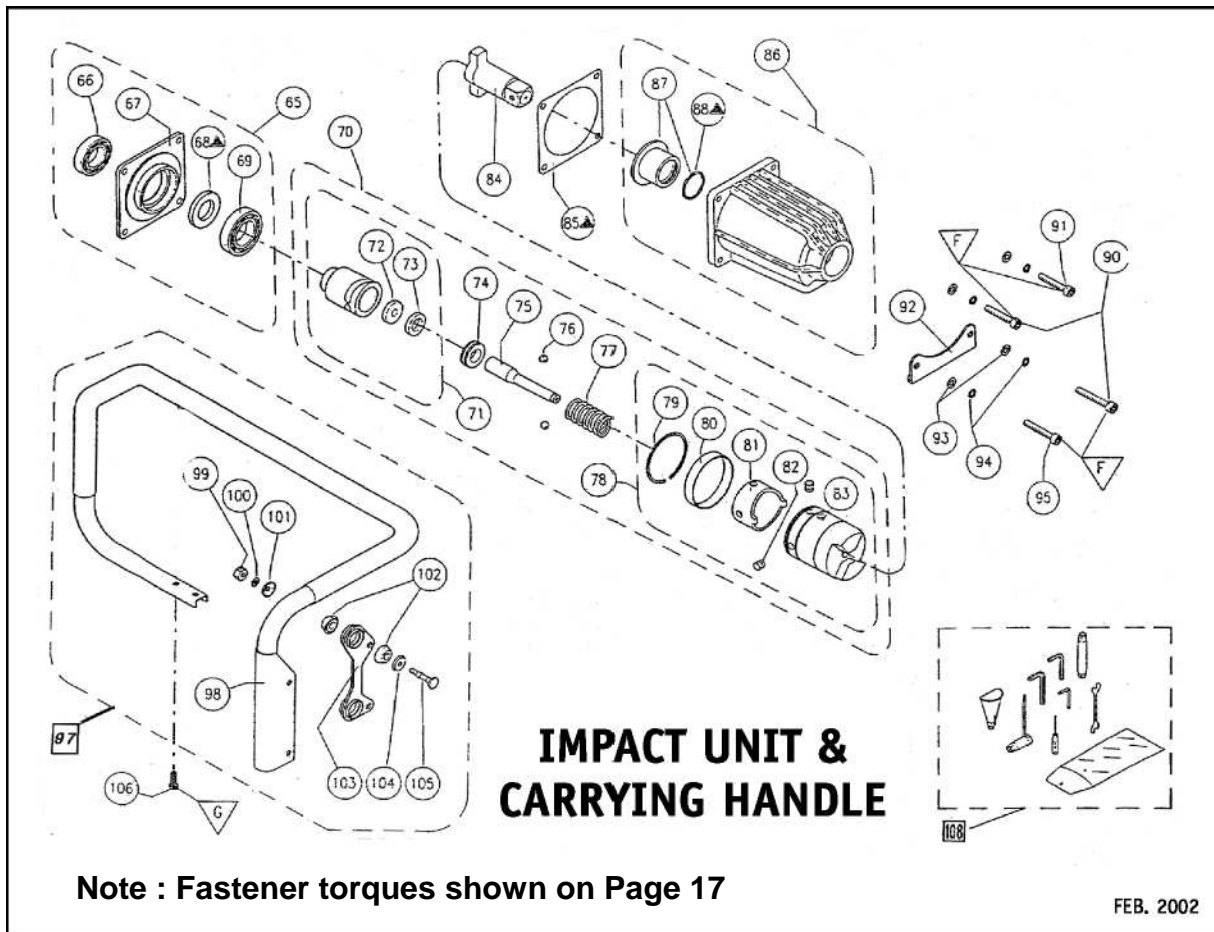

















IMPACT UNIT & CARRYING HANDLE PARTS LIST

DRAWING PART REF .	NO.	DESCRIPTION	DRAWING PART REF .	NO.	DESCRIPTION
65	035303	Ring Flange complete	86	035301	Nose Casing complete
66	135558	Bearing	87	033005	Nose Bush with 'O' Ring
67	035561	Ring Flange	88	23541370	'O' Ring
68	135559	Oil Seal	90	135575	Screw (2)
69	135531	Bearing	91	135564	Screw
70	035309	Impact complete	92	135153	Footrest
71	035565	Catch	93	135571	Washer (7)
72	035586	Stop Bush	94	135570	Washer (7)
73	035585	Guide Bush	95	135563	Screw
74	135532	Bearing	97	28004030	Handle complete
75	035567	Central Shaft	98	26205100	Handle
76	135539	Steel Ball (2)	99	23102061	Lock Nut (2)
77	035566	Spring	100	24002060	Washer (2)
78	035302	Hammer Assembly complete	101	40003290	Rubber Mount Washer (2)
79	135533	Seeger Ring (2)	102	5400227	Rubber Mount (4)
80	035536	Steel Ring	103	26502000	Bracket
81	035538	Cam	104	5400563	Rubber Mount Washer (2)
82	035537	Steel Plug (4)	105	25800080	Screw (2)
83	035568	Hammer	106	23050620	Screw (2)
84	035572	Anvil	108	11401010	Maintenance Toolkit
85	035562	Gasket			

18. MASTER IMPACT & GEARBOX UNIT NOTES

1. FASTENER INFORMATION & TORQUES

See drawings on Pages 14 and 16.

Pos	Screw Head Sizes	Removal Direction	Torque Settings		Notes
			Nm	Ft./lbs.	
A	 13mm	 OFF	23	16	
B	 19mm	 OFF	33	23	
C	 5mm	 OFF	16	11	
D	 13mm	 OFF	33	23	
E	 4mm	 OFF	6	4	Loctite 243
F	 6mm	 OFF	33	23	
G	 8mm	 OFF	6	4	Loctite 243
H	 4mm	 OFF	9	6	Hot Motor Muffler

2. Impact Unit Complete 2870.0650

3. Toolkit 1140.1010

The Toolkit contains the following.

Toolkit in Bag Complete	TK1
Allen Key 4mm	TK2 for 5mm Cap Screws
Allen Key 5mm	TK3 for 6mm Cap Screws
Allen Key 6mm	TK4 for 8mm Cap Screws
Double Open Ended Spanner 13mm x 10mm	TK5 for Clutch Nut and M10 Hex Screw respectively TK7
Spark Plug	TK8 Minor Carburettor adjustments
Spanner	TK9
Screwdriver	
Fuel Funnel	

4. PART NUMBER CHANGES

Old	Description	New
28101031	Motor Complete	2810.1030
23430520	Oil Seal	2343.0420

5. PARTS ORDERING PROCEDURE

When ordering parts please show Quantity, Description and Part Number e.g.

QTY	DESCRIPTION	PART NO.
4	Fuel Filters	4001.9100

19. ROLL BAR HANDLE KIT 2800.4045

Carrying Handle fitted to Roll Bar Handle Kit 2800.4045 to assemble on the Master 35® (without 8mm – 5/16" hole)

Place the Wrench on a working table.

Clean the area of the Carrying Handle where the hole will be drilled.

Fold with accuracy the label by the black line at 61.2mm



Picture 1

Hole Location

Remove the adhesive protection and stick the label fitting together the upper fixing Screw of the Carrying Handle with the fold of the label.



Picture 2

Hole Drilling

The label shows the correct spot where you have to drill. Drill 8mm (5/16") paying attention to hold the Bit perpendicular to the Handle and not to damage the Starter Housing

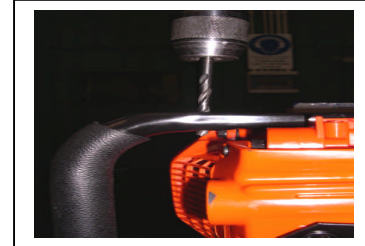

Picture 3

How to fit the Roll Bar Handle Kit to the Carrying Handle 2800.4030 (without 8mm – 5/16" hole)

Fold with accuracy the label in correspondence of the black line at 110mm.

Remove the adhesive protection behind the label and stick it fitting together the extremity of the Carrying Handle and the fold of the label.



Picture 4

Hole Drilling

The label shows the correct position of the perforation. Drill 8mm (5/16") paying attention to hold the Drill Bit perpendicular to the Carrying Handle.

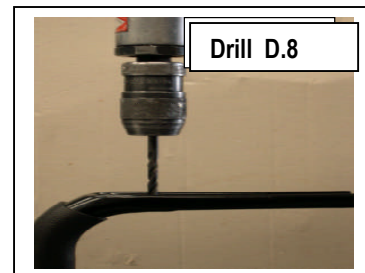

Picture 5

How to fit the Handle to the Master 35 (with 8mm – 5/16" hole)

Position 1 Replace the two Screws with the M6 longer ones in the package; insert the protections as per the picture and tighten using the original Washers and Nuts.

Position 2 Insert the short M6 Screw into the 8mm hole (5/16"). The head of the Screw remains at the inside of the Carrying Handle. Fix the end of the protection with the new M6 Nut.

Position 3 Remove the M5 Screw that fixes the Wear Plate to the Tank at the Handle side. Insert from outside the new M5 Screw; fix with the original Threaded Washer.



Picture 6

20. FAULT FINDING

PROBLEM	POSSIBLE CAUSE	ACTION
MOTOR WILL NOT START	1) Empty fuel tank 2) Incorrect fuel/oil mix 3) Control switch in stop position 4) Choke lever in Run position 5) Oiled up spark plug 6) Air filter choked 7) Fuel filter choked 8) Decompression Button not closing	Open fuel tank carefully to release any pressure and fill tank. Drain tank and fill with correct mixture Set to I. Set to Start position. Remove and clean or replace and check fuel/oil mixture. Clean or replace Clean or replace Remove and clean or replace.
MOTOR STOPS DURING USE	1) Empty fuel tank 2) Idle speed too low 3) Air filter choked 4) Fuel filter choked 5) Decompression Button activated	As above Adjust idle speed screw As above As above Restart as normal
MOTOR SMOKES BADLY	1) Too much oil in fuel/oil Mixture	Drain fuel tank and refill with correct mix.
UNABLE TO ENGAGE GEARS	1) Idle speed too high 2) Damaged selector pin 3) Broken or damaged gears	Adjust idle speed screw Remove gear selector and check pin. Empty gearbox oil and inspect gears.
MOTOR OVERHEATS OR SEIZES UP	1) Straight petrol/gasoline used 2) Cooling ducts in cylinder blocked 3) Worn or damaged cylinder/piston assembly	Allow to cool and check cylinder & piston for damage Clean until clear Dismantle and renew parts.
IMPACT OVERHEATS OR SEIZES UP	1) Damaged gearbox bearings 2) Damaged or broken gears 3) Insufficient oil in gearbox 4) Broken hammer or anvil lug.	Strip and replace. As above. Inspect inner parts then fill gearbox with oil. Strip and replace broken parts.
WRENCH HAS REDUCED PERFORMANCE	1) Worn or damaged hammer/anvil parts 2) Air filter blocked 3) Fuel filter blocked 4) Clutch slipping	Check strike faces and inner hammer parts and replace if necessary. Clean or replace Clean or replace Strip and check clutch and clutch ring for wear.

21. WORKSHOP EQUIPMENT

To carry out repairs and maintenance work effectively.

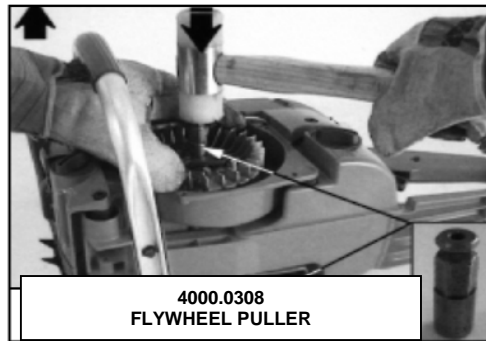
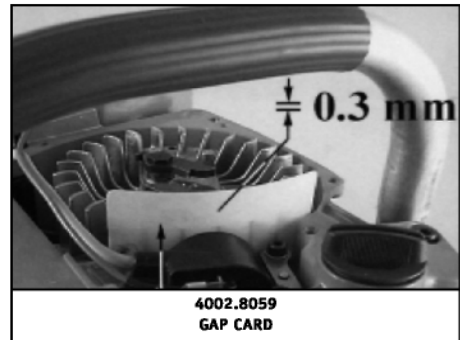
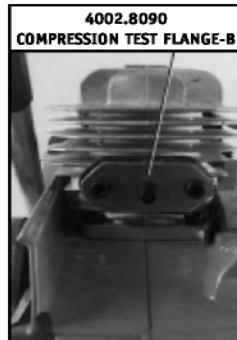
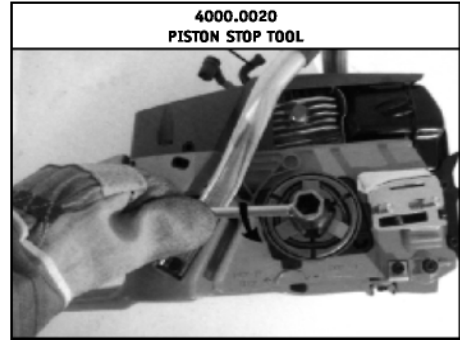
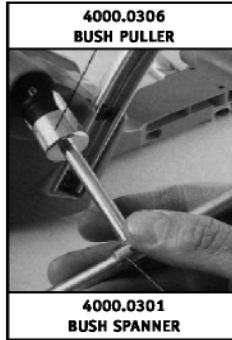

Not illustrated - **PULLER 4002.8070**
Used for removal of Bearing Flange 25400130

1. METAL CARRYING BOX

Strong Metal Carrying Box with full length hinged lid, lockfast fitting, twin carrying handles and anti-slip rubber base. Holds an Impact Wrench, Sockets, Augering Attachment, Bits, Clips and Oil

Weight 12.04 Kgs
Dimensions 590 x 455 x 296mm
(23¹/₄" x 18" x 11¹/₂")



2. IMPACT ACCESSORIES

STANDARD AND DEEP RAILWAY QUALITY

Hexagon 21 to 46mm, Square 21 to 25mm
Rectangular 19 x 17, 25 x 18 and 28 x 21mm
Bi-Square 7/8" to 2 1/4"

EXTENSIONS 125 to 450mm (6" to 18" long),
UNIVERSAL JOINTS, MAXI CLIPS, RUBBER RINGS, STEEL PINS.

All Square Drivces and sizes available on request



3. AUGER ACCESSORIES

SAFETY QUICK RELEASE AUGERING ATTACHMENT

For Hexagon and Round Shank Bits

AUGER BITS

Scotch Nose and Reverse Cutter

10 to 22mm dia for drilling holes in all types of timber Railway Sleepers

Special shanks and lengths available on request



Buy your GENUINE SPARE PARTS & ACCESSORIES FROM



Accessories		22
	Auger Bits	22.3
	Impact Sockets	22.2
	Metal Carrying Box	22.1
	Safety Quick Release	
	Augering Attachment	22.3
Dismantling Impact Unit		14
	Clutch & Motor Flange	14.2
	Clutch Support Flange	14.1
	Gearbox	14.4
	Hammer Complete	14.5
	Seal & Bearings in Clutch	14.3
Dismantling Motor		8
	Air Filter	8.1
	Carburettor	8.7
	Crankcase from Fuel Tank	8.10
	Crankshaft	8.11
	Cylinder & Piston	8.9
	Exhaust Guard & Muffler Assembly	8.6
	Flywheel	8.5
	Fuel Primer	8.3
	Motor from Impact Unit	8.8
	Starter Recoil Spring	8.4
	Top Cover	8.2
Exploded Drawings, Parts List and Notes		
	Impact and Gearbox	14 – 18
	Motor	9 – 13
Fastener Information		18
Fault Finding		20
Operating Controls	Illustrations	4
Operating Controls		4
	Choke Lever	4.3
	De-Compression Button	4.12
	Forward/Reverse Control Knob	4.7
	Fuel Filler Cap	4.11
	Fuel Primer Bulb	4.2
	Half Speed Lever	4.6
	Oil Filler Plug	4.10
	On/Off Control Switch	4.1
	Recoil Starter	4.4
	Square Drive	4.8
	Throttle Trigger	4.5
	Torque Setting Lever	4.9

Roll Bar Handle Kit 2800.4045		19
Routine Service		7
	Air Filter	7.2
	Fuel Filter	7.3
	Gearbox Oil	7.5
	Grease Hammer & Anvil	7.6
	Starter Cord	7.4
	Routine Maintenance Instructions	7.7
	Spark Plug	7.1
Safety Precautions		3
Start/Stop Operations		6
	Fuel Mixture	6.1
	Operating the Wrench	6.4
	Preparation for Start-up	6.2
	Re-fuelling	6.6
	Starting Wrench	6.3
	Stopping the Wrench	6.5
	Tuning	6.7
Technical Information		2
	Bolt Capacity	2.2
	Dimensions	2.3
	Exhaust Emission Levels	2.5
	Gearbox	2.6
	Ignition	2.7
	Impact Mechanism	2.8
	Motor	2.4
	Noise	2.9
	Square Drive	2.10
	Vibration	2.11
	Weight	2.12
	Toolkit	18.3
Workshop Equipment	Workshop Equipment	21
Uses		1

AIRTEC
INTERNATIONAL LTD

Couper Street, Glasgow G4 0DL United Kingdom

Tel: 44 (0)141 552 5591

Fax: 44 (0) 141 552 5064

E-mail: enquiries@airtecintl.co.uk

Website: www.airtecinternational.com